

DESCH Hadeflex® X / TX / F

Flexible Couplings



HX 11 - GB

Flexible Hadeflex®-couplings

The flexible DESCH Hadeflex® couplings are claw couplings with flexible elements to provide a torsionally flexible connection for shafts. The flexible elements excel in their wear resistance, their oil, ozone and ageing resistance and their temperature resistance from -20°C to +80°C. Thanks to their flexibility, impacts, rotary vibrations and noises are effectively absorbed. The flexible elements are dimensioned such that radial, axial and angular movements between the two halves of the coupling are cancelled out. The flexible DESCH Hadeflex® couplings are of the plug-in type for installation and do not involve any particularly rigorous requirements with respect to alignment accuracy. The balancing quality is, in accordance with DIN-ISO 1940, in the quality range G 16. DESCH Hadeflex® couplings can be used in the whole of machine construction wherever a reliable shaft connection is needed between motor and machine.

Type X

The DESCH Hadeflex® version X coupling is fail-safe up to the fracture moment of the cast iron transmission cam and this provides maximum operational safety. The coupling star can be supplied with hardness 92 Shore A and 98 Shore A. With the fixed position of the coupling star its deformability in axial direction is free, and so no damaging axial forces can act on the machine bearing even with alternating torque.

Type TX – with taper bush

The DESCH Hadeflex® version TX coupling combines the outstanding features of the flexible couplings with the advantages of the taper bush system: fast and easy installation for a torsionally flexible connection between shafts and elimination of shaft balancing errors. The TX version with taper bush has the advantage that even with greater shaft tolerances there is a backlash-free and at the same time axial fixing of the shaft. In addition the close sliding fit makes axial alignment of the coupling easier. The coupling star can be replaced by a simple axial displacement of the coupling halves without having to disassemble the machines connected.

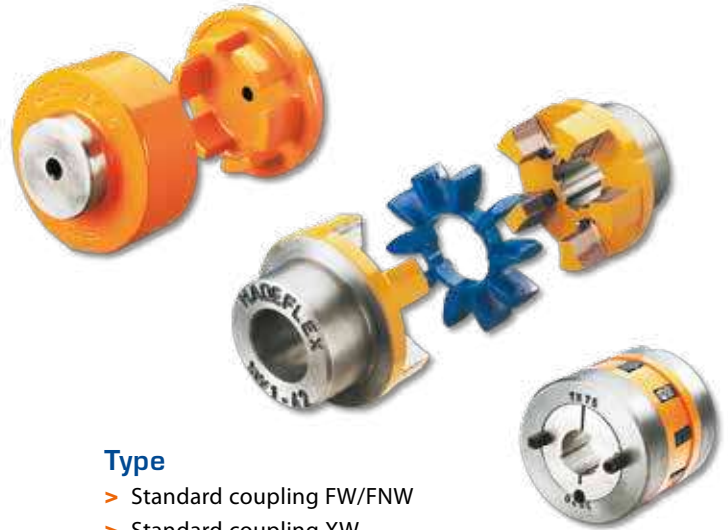

Type

- > Standard coupling FW/FNW
- > Standard coupling XW
- > Taper-bush type TX

Type F

The Hadeflex® version F coupling is manufactured in two-piece and three-piece variants. With the two-piece coupling (FW series) it is possible to install packages after axial displacement of the drive engines or machines. With the three-piece coupling (FNW series) it is possible to install packages without axial displacement of the drive engine or machine.

Type TX 03

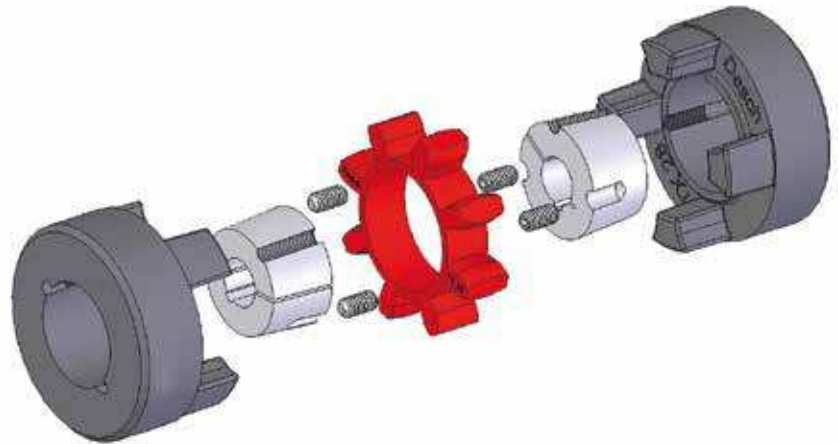
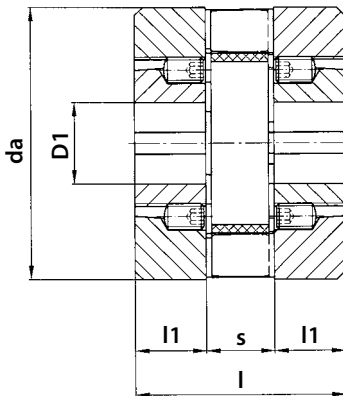

Size	Bush No.	D1		da	l	l1	s	Max. rotational speed min ⁻¹	Weight ⁴⁾ kg	Moments of inertia ⁴⁾ kgm ²	max. shaft misalignment ³⁾		
		min mm	max mm								radial ΔK_r mm	axiale ΔK_a mm	angular ΔK_w Grad
28	1108	10	28	71	66	23	20	9900	1,26	0,0004	0,3	0,5	0,7
42	1610	14	42	100	77	26	25	7000	2,92	0,0020	0,4	1,0	0,7
60	2517	16	60	147	120	45	30	4700	10,5	0,0158	0,5	1,0	0,7
75	3020	25	75	181	142	51	40	3800	18,9	0,0437	0,6	1,0	0,7
90	3535	35	90	217	224	89	46	3200	44,0	0,144	0,7	1,0	0,7
110	4545	55	110	271	284	115	54	2500	88,1	0,450	0,9	1,0	0,7

Size	Torque 92° Shore A black / 98° Shore A red ¹⁾				Torsion spring rigidity C dyn Nm / rad							
	92° nominal-T _{KN}	98° nominal-T _{KN}	max T _{KN max}	changing T _{KN} ²⁾	92° Shore	92° Shore	92° Shore	92° Shore	98° Shore	98° Shore	98° Shore	98° Shore
	Nm	Nm	Nm	Nm	1/4 T _{KN}	1/2 T _{KN}	3/4 T _{KN}	1/1 T _{KN}	1/4 T _{KN}	1/2 T _{KN}	3/4 T _{KN}	1/1 T _{KN}
28	63	80	190	25	2450	2950	3900	5350	3100	4450	7350	11750
42	220	280	660	80	7900	9850	13550	18750	10450	15550	26400	41600
60	630	800	1900	230	22600	28400	38300	50000	30350	44450	73300	108300
75	1250	1500	3750	450	44950	62850	81500	99350	58050	80600	123750	178500
90	2500	3000	7500	825	90100	130000	176500	223500	117900	173800	253300	355900
110	4000	5000	12000	1500	175700	223400	279200	337400	190600	254100	348500	477500

1) Torques for shaft fit with keyway – 2) Maximum alternating torque up to f= 10Hz – 3) The values mentioned are valid for 600 rpm and may occur only separately. At multiple misalignments or higher speeds the values must be reduced (see page S.9) – 4) Weight and moments of inertia apply for max. drill holes; coupling half materials: EN-GJL-250 (GG-25) in accordance with DIN EN 1561.

Taper-bushes with keyway acc. to DIN 6885/1

tolerance JS9

Taper-Bush No.	Bore \varnothing of available Taper-bushes mm											
	10	11	12	14	16	18	19	20	22	24	25	28*
1108	14	16	18	19	20	22	24	25	28	30	32	35
1610	38	40	42*									
2517	16	18	19	20	22	24	25	28	30	32	35	38
	40	42	45	48	50	55	60					
3020	25	28	30	32	35	38	40	42	45	48	50	55
	60	65	70	75								
3535	35	38	40	42	45	48	50	55	60	65	70	75
	80	85	90									
4545	55	60	65	70	75	80	85	90	95	100	105	110

* These bohrholes are with flat – keyway DIN 6885/3

Technical data XW1

Size	Torque 92° Shore A natur/98° Shore A blue ¹⁾				Torsion spring rigidity C dyn in Nm / rad							
	92° nominal-T _{KN}	98° nominal-T _{KN}	Max T _{KN max}	changing T _{KW} ²⁾	92° Shore	92° Shore	92° Shore	92° Shore	98° Shore	98° Shore	98° Shore	98° Shore
	Nm	Nm	Nm	Nm	1/4 T _{KN}	1/2 T _{KN}	3/4 T _{KN}	1/1 T _{KN}	1/4 T _{KN}	1/2 T _{KN}	3/4 T _{KN}	1/1 T _{KN}
24	40	52	120	15	2150	3300	4200	4800	5550	8650	16600	29400
28	63	80	190	25	2850	4300	6050	8100	7000	10750	19650	33300
32	100	120	300	35	3700	6000	8500	11100	8300	12850	23800	40500
38	160	200	480	60	5800	8800	12600	16800	11600	17600	31850	55800
42	220	280	660	80	8100	11600	17400	25200	14250	22500	42000	75400
48	320	400	960	120	10400	16800	24800	34700	16400	28700	49950	79200
55	450	600	1350	180	13250	23500	34000	44550	20650	39700	69600	109400
60	630	800	1900	230	17600	32600	46800	55900	24900	50800	90250	140700
65	900	1000	2700	300	29200	46800	66400	85600	35500	72500	120400	174800
75	1250	1500	3750	450	42250	69200	95650	124200	46800	97400	165600	238600
85	1800	2250	5400	675	55900	94450	135450	177000	61100	120400	222300	350300
100	3000	3800	9000	1125	110600	166100	220400	268900	93600	192500	330000	482600
110	4000	5000	12000	1500	120100	220100	309500	386900	130500	251000	439500	641000
125	5600	7000	16800	2200	220500	331700	446000	548600	229700	358000	616500	821000
140	8000	10000	24000	3000	292200	430100	602400	723500	255200	465100	785200	1192600
160	12500	15000	37500	4500	319000	547000	847500	1273000	364000	640000	1018000	1500000

Size	Max. shaft misalignment ³⁾		
	radiale ΔK_r mm	axiale ΔK_a mm	angular ΔK_w Grad
24	0,3	1,2	0,7
28	0,3	1,2	0,7
32	0,3	1,2	0,7
38	0,4	1,5	0,7
42	0,4	1,5	0,7
48	0,4	1,5	0,7
55	0,5	1,8	0,7
60	0,5	1,8	0,7

Size	Max. shaft misalignment ³⁾		
	radiale ΔK_r mm	axiale ΔK_a mm	angular ΔK_w Grad
65	0,5	1,8	0,7
75	0,6	2,1	0,7
85	0,7	2,1	0,7
100	0,8	2,4	0,7
110	0,9	2,4	0,7
125	1,0	3,0	0,7
140	1,1	3,0	0,7
160	1,2	3,0	0,7

1) Torques for shaft fit with keyway – 2) Maximum alternating torque up to $f=10\text{Hz}$ – 3) The values mentioned are valid for 600 rpm and may occur only separately. At multiple misalignments or higher speeds the values must be reduced (see page S.10)

Type XW1

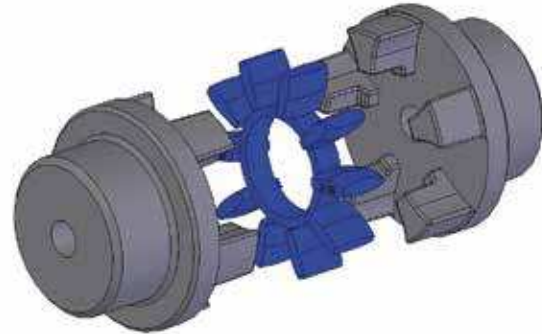
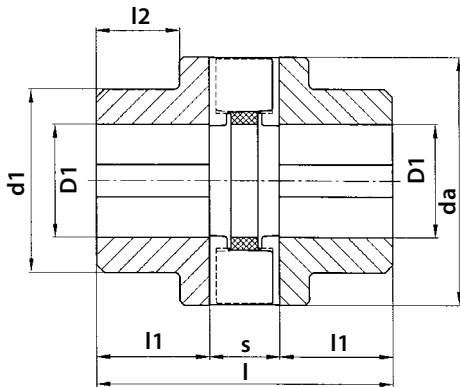

Size	D1 pre.	D1 (H7) ¹⁾		da	d1	l	l1	l2	s	Max. rotational speed min ⁻¹	Weight ²⁾ kg	Moments of inertia ²⁾ kgm ²
		min. mm	max. mm									
24*	–	–	24	55	55	66	24	–	18	12500	0,55	0,0002
28*	–	–	28	62	62	76	28	–	20	11100	0,76	0,0004
32	–	–	32	70	52	86	32	22	22	9800	1,09	0,0006
38	14	16	38	84	60	100	38	27	24	8100	1,76	0,0014
42	14	16	42	92	68	110	42	31	26	7400	2,38	0,0024
48	17	19	48	105	76	124	48	36	28	6500	3,38	0,0042
55	17	19	55	120	88	140	55	43	30	5700	4,89	0,0080
60	22	24	60	130	96	152	60	47	32	5200	6,29	0,012
65	24	26	65	142	104	165	65	51	35	4800	8,15	0,018
75	30	32	75	165	120	190	75	59	40	4100	12,60	0,038
85	40	42	85	185	136	214	85	68	44	3700	17,90	0,068
100	58	60	100	220	160	250	100	80	50	3100	29,30	0,156
110	68	70	110	240	176	275	110	88	55	2800	38,50	0,246
125	68	70	125	275	200	310	125	100	60	2500	56,70	0,470
140	78	80	140	310	224	345	140	113	65	2200	79,00	0,824
160	88	90	160	360	255	395	160	130	75	1900	119,40	1,654

1) Drill holes H7 with keyway in accordance with DIN 6885/1; tolerance zone JS9 and set screws on the keyway

2) The information concerning weights and moments of mass inertia apply for max. holes per coupling; coupling half materials: EN-GJL-250 (GG-25) in accordance with DIN EN 1561

Allocation to IEC motor XW1

Power P of the IEC motor and allocated Hadeflex® couplings X								Shaft ends		
Size of the tree phase motor	3000 min ⁻¹ P Hadeflex® kw Size		1500 min ⁻¹ P Hadeflex® kw Size		1000 min ⁻¹ P Hadeflex® kw Size		750 min ⁻¹ P Hadeflex® kw Size		Form E DIN 748 part 3 d × l at speed approx.	
	3000 min ⁻¹		1500 min ⁻¹		1000 min ⁻¹		750 min ⁻¹		3000 min ⁻¹	1500 min ⁻¹ and less
56	0,09	24	0,06	24	0,037	24	-		9 × 20	
	0,12	24	0,09	24	0,045	24	-			
63	0,18	24	0,12	24	0,06	24	-		11 × 23	
	0,25	24	0,18	24	0,09	24	-			
71	0,37	24	0,25	24	0,18	24	0,09	24	14 × 30	
	0,55	24	0,37	24	0,25	24	0,12	24		
80	0,75	24	0,55	24	0,37	24	0,18	24	19 × 40	
	1,1	24	0,75	24	0,55	24	0,25	24		
90 S	1,5	24	1,1	24	0,75	24	0,37	24	24 × 50	
90 L	2,2	24	1,5	24	1,1	24	0,55	24	24 × 50	
100 L	3	28	2,2	28	1,5	28	0,75	28	28 × 60	
	-		3	28	-		1,1	28		
112 M	4	28	4	28	2,2	28	1,5	28	28 × 60	
132 S	5,5	38	5,5	38	3	38	2,2	38	38 × 80	
	7,5	38	-		-		-			
132 M	-		7,5	38	4	38	3	38	38 × 80	
	-		-		5,5	38	-			
160 M	11	42	11	42	7,5	42	4	42	42 × 110	
	15	42	-		-		5,5	42		
160 L	18,5	42	15	42	11	42	7,5	42	42 × 110	
180 M	22	48	18,5	48	-		-		48 × 110	
180 L	-		22	48	15	48	11	48	48 × 110	
200 L	30	55	30	55	18,5	55	15	55	55 × 110	
	37	55	-		22	55	-			
225 S	-		37	60	-		18,5	60	55 × 110	60 × 140
225 M	45	55	45	60	30	60	22	60	55 × 110	60 × 140
250 M	55	60	55	65	37	65	30	65	60 × 140	65 × 140
280 S	75	65	75	75	45	75	37	75	65 × 140	75 × 140
280 M	90	65	90	75	55	75	45	75	65 × 140	75 × 140
315 S	110	65	110	85	75	85	55	85	65 × 140	80 × 170
315 M	132	65	132	85	90	85	75	85	65 × 140	80 × 170
315 L	160	75	160	85	110	85	90	100	65 × 140	80 × 170
	200	75	200	100	132	100	110	100		
	250	85	250	100	160	100	132	110	75 × 140	95 × 170
355 L	315	85	315	110	200	110	160	110		
	-		-		250	125	200	125		
400 L	355	100	355	125	315	125	250	140	80 × 170	100 × 210
	400	100	400	125	-		-			

As proposed in the table for surface cooled three-phase motors with cage rotor acc. to DIN 42673, page1 (data for motor 56, 63, 71, 80, 315 L, 355 L, 400 L, see catalogue Siemens). This allocation is a preliminary selection for normal conditions of operation. For conditions of operation under shock and changing loads the selection must be made according to the following. (see page S.10)

Technical data FW-FNW

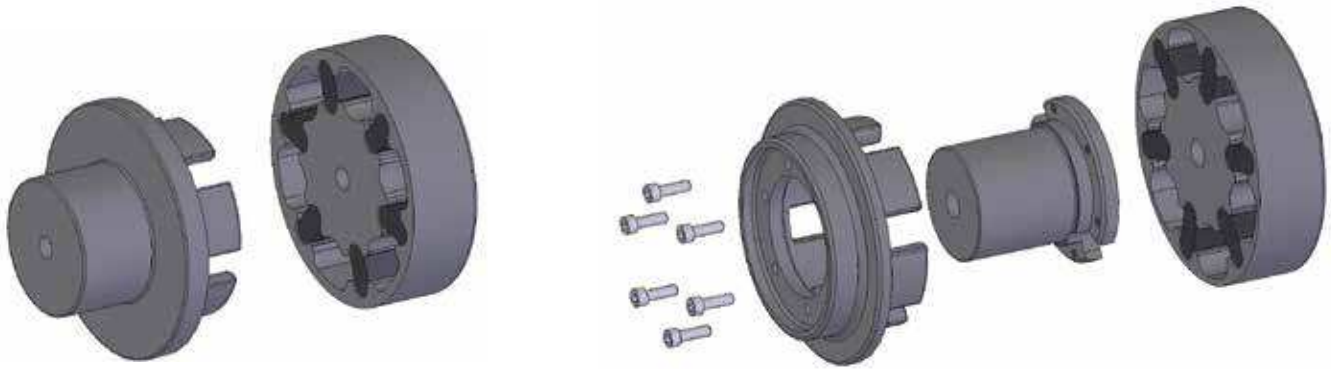

Size	Torque Perbunan rigidity 80° Shore A ¹⁾			Torsion spring rigidity C dyn Nm / rad				Max. shaft misalignment ³⁾		
	nominal-T _{KN} Nm	max T _{KN max} Nm	changing T _{KW} ²⁾ Nm	1/4 T _{KN}	1/2 T _{KN}	3/4 T _{KN}	1/1 T _{KN}	radiale Δ K _r mm	axiale Δ K _a mm	angular Δ K _w mm
1	12	18	3	900	1100	1250	1450	0,3	1	0,3
2	16	24	4	1150	1450	1750	2150	0,3	1	0,3
3	24	36	6	1600	2050	2550	3100	0,3	3	0,3
4	30	45	7	2050	2550	3150	3700	0,4	3	0,3
5	50	75	12	3550	4400	5350	6400	0,4	3	0,3
6	110	165	27	7700	9700	11800	13900	0,4	3	0,3
7	150	225	37	10550	13250	16100	19100	0,5	3	0,3
8	310	465	77	21750	27150	32900	39350	0,5	4	0,3
9	480	720	120	26400	34950	43800	52550	0,5	4	0,3
9 a	860	1290	215	39100	54400	67500	82650	0,5	4	0,3
10	1220	1830	305	44400	64450	85300	108350	0,6	5	0,3
10 a	1760	2640	440	76100	91600	116200	150650	0,6	5	0,3
11	2480	3720	620	76900	92500	131950	188500	0,7	5	0,3
12	3830	5745	957	114550	168100	245150	338900	0,8	6	0,3
13	5730	8595	1432	171250	242050	346850	483950	0,9	6	0,3
14	9550	14325	2387	275600	394150	567500	799450	1,0	6	0,3
15	12880	19320	3220	370750	529850	766250	1090700	1,1	6	0,3
16	20000	30000	5000	566800	809650	1178450	1671850	1,2	6	0,3

1) Torques for shaft fit with keyway

2) Maximum alternating torque up to f= 10Hz

3) The values mentioned are valid for 600 rpm and may occur only seperately.

At multiple misalignments or higher speeds the values must be reduced (see page 10).

Type FW

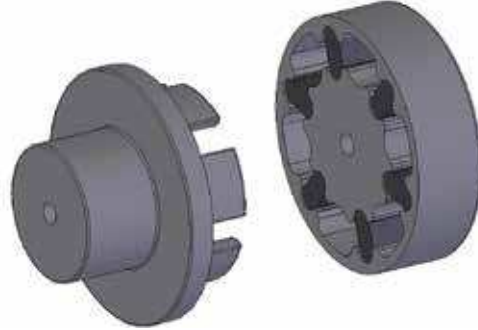
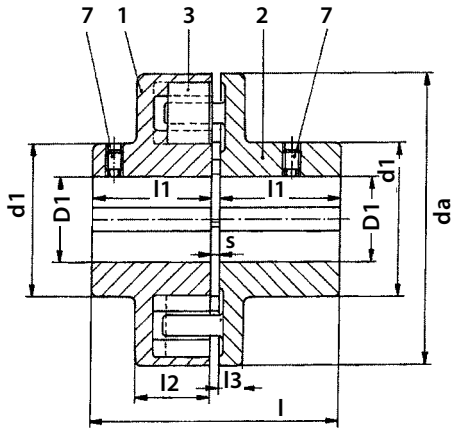

Size	D1	D1 (H7) ¹⁾		da	d1	l	l1	l2	l3	s	Max. rotational min ⁻¹	Weight ²⁾ kg	Moments of inertia ²⁾ kgm ²
	pre.	min mm	max mm	mm	mm	mm	mm	mm	mm	mm			
1	-	-	15	75	35	78	38	30	8	2	9 700	1,08	0,00065
2	-	-	18	80	45	82	40	30	10	2	9 000	1,44	0,00098
3	-	-	28	90	50	88	43	31	10	2	7 300	1,78	0,00164
4	-	-	30	100	60	92	45	32	10	2	6 600	2,45	0,0026
5	11	13	38	120	65	102	50	35	12	2	5 500	3,56	0,0058
6	16	18	42	150	70	122	60	42	12	2	4 200	6,07	0,0147
7	19	21	50	170	90	143	70	44	14	3	3 900	9,35	0,029
8	24	26	65	210	110	163	80	53	16	3	3 100	16,30	0,078
9	32	34	80	250	140	223	110	55	18	3	2 700	30,00	0,191
9 a	38	40	90	280	160	223	110	66	21	3	2 400	40,10	0,331
10	43	45	105	300	180	263	130	68	22	3	2 100	52,30	0,488
10 a	53	55	110	340	200	303	150	70	24	3	1 950	77,80	0,892
11	58	60	125	370	215	323	160	72	25	3	1 800	93,90	1,286
12	68	70	140	440	245	364	180	96	28	4	1 600	149,40	2,94
13	88	90	160	500	280	404	200	100	33	4	1 350	216,00	5,43

- 1) Drill holes H7 with keyway in accordance with DIN 6885/1; tolerance zone JS9 and set screws on the keyway
 2) The information concerning weights and moments of mass inertia apply for max holes per coupling.;
 coupling half materials: EN-GJL-250 (GG-25) in accordance with DIN EN 1561.

Type FNW

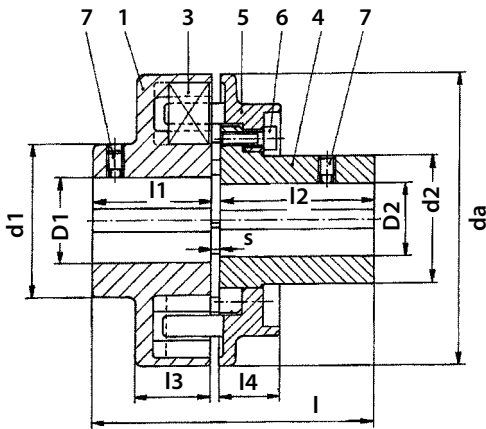

Size	D1 (H7) ¹⁾		D2 (H7) ¹⁾		da	d1	d2	l	l1	l2	l3	l4	s	Max. rotational min ⁻¹	Weight ²⁾ kg	Moments of inertia ²⁾ kgm ²
	min mm	max mm	min mm	max mm												
6	18	42	18	35	150	75	65	142	60	80	42	28	2	4 200	6,57	0,0149
7	21	50	21	45	170	90	72	163	70	90	44	35	3	3 900	9,66	0,029
8	26	65	26	55	210	110	97	183	80	100	53	35	3	3 100	17,10	0,078
9	34	80	34	75	250	140	126	223	110	110	55	42	3	2 700	29,60	0,186
9 a	40	90	40	80	280	160	130	243	110	130	66	49	3	2 400	39,50	0,316
10	45	105	45	90	300	180	150	263	130	130	68	49	3	2 100	50,00	0,456
10 a	55	110	55	100	340	200	180	303	150	150	70	49	3	1 950	75,30	0,843
11	60	125	60	120	370	215	205	323	160	160	72	58	3	1 800	95,40	1,294
12	70	140	70	130	440	245	230	364	180	180	96	64	4	1 600	151,40	2,93
13	90	160	90	160	500	280	280	404	200	200	100	70	4	1 350	222,60	5,54
14	100	180	100	180	560	310	310	444	220	220	102	76	4	1 100	289,90	9,26
15	130	200	130	200	620	340	340	524	260	260	105	86	4	1 100	402,60	15,23
16	-	220	-	220	710	375	375	566	280	280	130	93	6	900	560,50	27,9

1) Drill holes H7 with keyway in accordance with DIN 6885/1; tolerance zone JS9 and set screws on the keyway
 2) The information concerning weights and moments of mass inertia apply for max holes per coupling.;
 coupling half materials: EN-GJL-250 (GG-25) in accordance with DIN EN 1561

Allowable misalignments

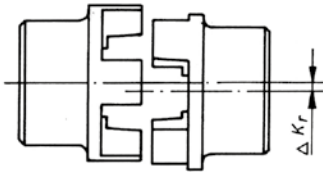

Radial misalignment

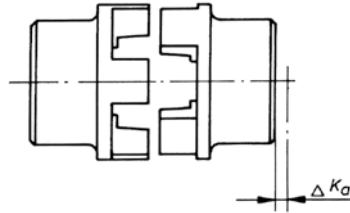

Axial misalignment

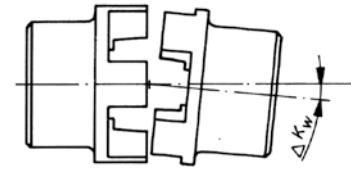

Angular misalignment

Reduction of the allowable values of misalignment when the combination of misalignments occur or at other rotational speeds:

$$\frac{\Delta W_r}{\Delta K_r} + \frac{\Delta W_a}{\Delta K_a} + \frac{\Delta W_w}{\Delta K_w} \leq 1 \quad = \text{Applies to speeds of 600 rpm}$$

$$\leq 0,8 \quad 601 - 1000 \text{ min}^{-1}$$

$$\leq 0,65 \quad 1001 - 1500 \text{ min}^{-1}$$

$$\leq 0,50 \quad 1501 - 3000 \text{ min}^{-1}$$

$\Delta K_{r/a/w}$ = allowable radial, axial or angular misalignment of the shafts resp. of the couplinghalves

$\Delta W_{r/a/w}$ = measured radial, axial or angular misalignment of the shafts resp. of the couplinghalves

Selection

The torque of the machine T_{AN} is determined by:

$$T_{AN} [\text{Nm}] = 9550 \times \frac{P_{\text{Motor}} [\text{kW}]}{n [\text{min}^{-1}]}$$

This torque T_{AN} multiplied by a safety factor „S“ depending on the application and the temperature factor ST (see table page 11) gives the required nominal coupling torque T_{KN} .

$$\text{result: } T_{KN} \geq S \times S_T \times T_{AN}$$

In case that bigger shock or changing load occur we recommend a revision according to DIN 740. An adequate calculation program is available. For such a revision the following information is required:

1. Kind of the driving machine
2. Kind of the driven machine
3. Power of driving and driven machines
4. Rotational speed of operation
5. Shock loads
6. Exciting loads
7. Moments of inertia of load- and driving sides
8. Starts per hour
9. Ambient temperature

Design example for IEC standard motors

Dates of the plant

Driving machine

Three-phase motor: 315L
Power of the motor: P = 110 kW
Rotation at speed: n = 1000 min⁻¹
Driven machine: Mixer
Ambient temperature +35°

Selection

XW1 Size 100 flexible spider 92° Shore A
 $T_{KN} = 3000 \text{ Nm}$
TX 03 Size 90 flexible spider 92° Shore A
 $T_{KN} = 2500 \text{ Nm}$
FW Size 11 $T_{KN} = 2480 \text{ Nm}$
FNW Size 11 $T_{KN} = 2480 \text{ Nm}$

Layout of the coupling

$$T_{AN} = 9550 \times \frac{110 \text{ kW}}{1000 \text{ min}^{-1}} = 1051 \text{ Nm}$$

$$T_{KN} = 1,75 \times 1,2 \times 1051 \text{ Nm} = 2207 \text{ Nm}$$

Safety factors "S"

Assignment of load characteristics according to type of working machine

DREDGERS	RUBBER MACHINERY	PUMPS
S Bucket conveyor	S Extruders	S Piston pumps
S Landing gear (caterpillar)	M Calenders	G Centrifugal pumps (light liquids)
M Landing gear (rail)	S Kneading mill	M Centrifugal pumps (viscous liquids)
M Manoeuvring winches	M Mixers	S Plunger pumps
M Pumps	S Rolling mills	S Press pumps
S Impellers		
S Cutter heads	WOOD WORKING MACHINES	STONE AND CLAY WORKING MACHINES
M Slewing gear	S Barkers	S Crusher
	M Planing machines	S Rotary ovens
GENERATORS, TRANSFORMERS	G Wood working machines	S Hammer mills
M Frequency transformers	S Saw frames	S Ball mills
M Generators		S Tube mills
M Welding generators	CRANES	S Beater mills
	G Luffing gear block	S Brick presses
CHEMICAL INDUSTRY	S Travelling gear	
M Cooling drums	G Hoist gear	TEXTILE MACHINES
M Mixers	M Slewing gear	M Batchers
G Agitators (liquid material)	M Derricking jib gear	M Printing and dyeing machines
M Agitators (semi-liquid material)		M Tanning vats
M Drying drums	PLASIC INDUSTRY MACHINES	M Willows
G Centrifuges (light)	M Extruders	M Looms
M Centrifuges (heavy)	M Calenders	
	M Mixers	COMPRESSORS
OIL INDUSTRY	M Crushers	S Piston compressors
M Pipeline pumps		M Turbo compressors
S Rotary drilling equipment	METAL WORKING MACHINES	
	M Plate bending machines	METAL ROLLING MILLS
CONVEYORS	S Plate straightening machines	S Plate shears
M Pit-head winches	S Hammers	M Manipulator for turning sheets
S Winding engines	S Metal planning machines	S Ingot pushers
M jointed-band conveyors	S Presses	S Ingot and slabbing-mill train
G Belt conveyors (bulk material)	M Shears	S Ingot handling machinery
M Belt conveyors (piece goods)	S Forging presses	M Wire drawing benches
M Band pocket conveyors	S Punch presses	S Descaling machines
M Chain conveyors	G Countershafts, line shafts	S Thin plate mills
M Circular conveyors	M Machine tools (main drives)	S Heavy and medium plate mills
M Load elevators	G Machine tools (auxiliary drives)	M Winding machines (strip and wire)
G Bucket conveyors for flour		S Cold rolling mills
M Passenger lifts	FOOD INDUSTRY MACHINERY	M Chain tractor
M Plate conveyors	G Bottling and container filling machines	S Billet shears
M Screw conveyors	M Kneading machines	M Cooling beds
M Ballast elevators	M Mash tubs	M Cross tractor
S Inclined hoists	G Packaging machines	M Roller tables (light)
M Steel belt conveyors	M Cane crushers	S Roller tables (heavy)
M Drag chain conveyors	M Cane cutters	M Roller straighteners
	S Cane mills	S Tube welding machines
BLOWERS, VENTILATORS	M Sugar beet cutters	M Trimming shears
M Rotary piston blowers	M Sugar beet washing machines	S Cropping shears
G Blowers (axial/radial)		S Continuous casting plant
M Cooling tower fans	PAPER MACHINES	M Rollers adjustment drive
M Induced draught fans	S Couches	S Manipulators
G Turbo blowers	S Glazing cylinders	
	M Pulper	LAUNDRIES
BUILDING MACHINERY	S Pulp grinders	M Tumblers
S Hoists	M Calenders	M Washing machines
G Concrete mixers	S Wet presses	
S Road construction machinery	S Willows	WATER TREATMENT
	S Suction presses	M Aerators
	S Suction rolls	M Screw pumps
	S Drying cylinders	

Operating factor "S"

Driving machines	Load characteristics of the working machine		
	G	M	S
Electric motors, turbines, hydraulic motors	1	1,25	1,75
Piston machines 4-6 cylinders, degree of nonuniformity 1:100-1:200	1,25	1,5	2
Piston machines 1-3 cylinders, degree of nonuniformity up to 1:100	1,5	2	2,5

Temperature factor "S_T"

θ [°C]	S _T
-20 < θ < +30	1,0
+30 < θ < +40	1,2
+40 < θ < +60	1,5
+60 < θ < +80	1,8



Unit B1
Whitwood Enterprise
Park
Speedwell Road
Castleford
West Yorkshire
WF10 5PX ENGLAND
TEL: 01977 603853
sales@ybcomponents.co.uk